

AD-A093 140

DURACELL INTERNATIONAL INC BURLINGTON MA LAB FOR PHYS--ETC F/G 10/3
LITHIUM-THIONYL CHLORIDE BATTERY.(U)

UNCLASSIFIED

DEC 80 A DEY, N HAMILTON, D WONG, D CUBBISON DAAB07-78-C-0563
DELET-TR-78-0563-7 NL

1 of 1
40-A
7-74-0

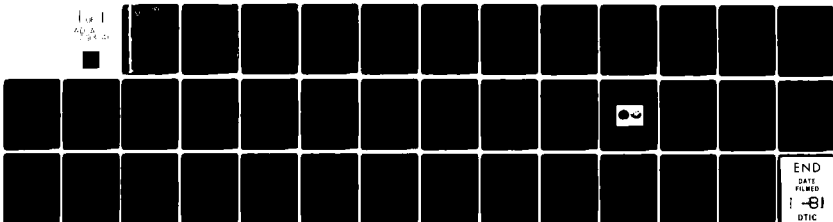

END
DATE
FILMED
-81
DTIC

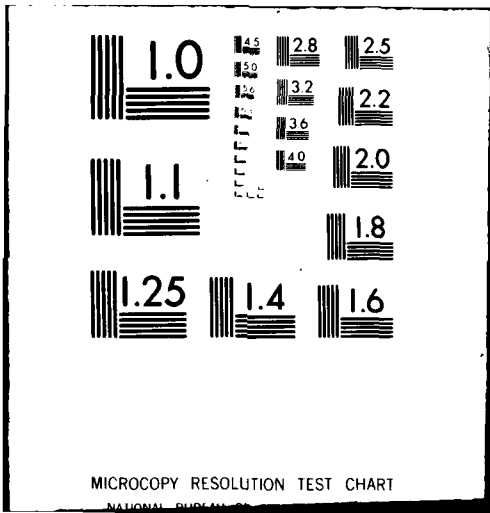

LEVEL

1
NW

A059281



Research and Development Technical Report

DELET - TR - 78 - 0563 - 7

AD A 093140

LITHIUM - THIONYL CHLORIDE BATTERY

A.N. DEY
N. HAMILTON
D. WONG
D. CUBBISON

DTIC
ELECTE
DEC 19 1980

DURACELL INTERNATIONAL INC.
LABORATORY FOR PHYSICAL SCIENCE
BURLINGTON, MA 01803

DECEMBER 1980

- 411/200

SEVENTH QUARTERLY REPORT
FOR PERIOD 1 MAY 1980 - 31 JULY 1980

DISTRIBUTION STATEMENT :
APPROVED FOR PUBLIC RELEASE ; DISTRIBUTION UNLIMITED

PREPARED FOR :
US ARMY ELECTRONICS TECHNOLOGY AND DEVICES LABORATORY

ERADCOM

US ARMY ELECTRONICS RESEARCH AND DEVELOPMENT COMMAND
FORT MONMOUTH, NEW JERSEY 07703

DDC FILE COPY

80 12 19 002

NOTICES

Disclaimers

The citation of trade names and names of manufacturers in this report is not to be construed as official Government indorsement or approval of commercial products or services referenced herein.

Disposition

Destroy this report when it is no longer needed. Do not return it to the originator.

HISA-FM-633-78

SECURITY CLASSIFICATION OF THIS PAGE (When Data Entered)

19 REPORT DOCUMENTATION PAGE		READ INSTRUCTIONS BEFORE COMPLETING FORM	
1. REPORT NUMBER 16 DELET-TR-78-0563-7 ✓	2. GOVT ACCESSION NO. AD-A093140	3. RECIPIENT'S CATALOG NUMBER	
4. TITLE (and Subtitle) 6 Lithium-Thionyl Chloride Battery.		5. TYPE OF REPORT & PERIOD COVERED 5/I/80 - 7/31/80	
7. AUTHOR(s) 10 A. N./Dey / N./Hamilton / D./Wong and D./Cubbison		8. CONTRACT OR GRANT NUMBER(s) 15 DAAB07-78-C-0563 ✓	
9. PERFORMING ORGANIZATION NAME AND ADDRESS Duracell International Inc. Laboratory for Physical Science Burlington, MA 01803		10. PROGRAM ELEMENT, PROJECT, TASK AREA & WORK UNIT NUMBERS 16 1L162705AH9411-219 17/14	
11. CONTROLLING OFFICE NAME AND ADDRESS U.S. Army Electronics Technology & Device Lab. ERADCOM Attn: DELET-PR Ft. Monmouth, New Jersey 07703		12. REPORT DATE 11 December 1980	
14. MONITORING AGENCY NAME & ADDRESS (if different from Controlling Office) 14 Quarters by Dept. 7, 1 May - 31 Jul 80		13. NUMBER OF PAGES 30 12/39	
16. DISTRIBUTION STATEMENT (of this Report) Approved for public release Distribution unlimited		15. SECURITY CLASS. (of this report) Unclassified	
17. DISTRIBUTION STATEMENT (of the abstract entered in Block 20, if different from Report)		15a. DECLASSIFICATION/DOWNGRADING SCHEDULE	
18. SUPPLEMENTARY NOTES			
19. KEY WORDS (Continue on reverse side if necessary and identify by block number) Inorganic Electrolyte battery, Thionyl Chloride, lithium, high rate D cell, high rate flat cylindrical cell, laser designator battery.			
20. ABSTRACT (Continue on reverse side if necessary and identify by block number) We have made final design changes to improve the anode connections of the flat cylindrical cell. We have also begun fabrication of parts needed for the assembly of at least forty such cells to be delivered to the sponsor in the form of five 8-cell batteries for Laser Designator Applications. We have further investigated the safety of the flat cell during voltage reversal on GLLD load at 3.2A and 20A. We also studied the rate capability retention of these cells after storage.			

411802

JOB

Table of Contents

	Page No.
I. Introduction	1
II. Laser Designator Battery	4
III. Flat Cylindrical Cell	5
Introduction	5
Experimental	6
Results & Discussion	7
IV. Conclusion	9
V. References	10

Accession For	
NTIS GRA&I	<input checked="" type="checkbox"/>
DTIC TAB	<input type="checkbox"/>
Unannounced	<input type="checkbox"/>
Justification	
By _____	
Distribution/	
Availability Codes	
Dist	Avail and/or Special
A	

Figure Captions

- Figure 1. Schematic diagrams for the pulse discharge in the new GLLD duty cycle.
- Figure 2. Schematic outline for the GLLD battery using 8 x 3" O.D. 0.90" thick flat cells.
- Figure 3. Lithium anode contact detail of finalized version of the flat cell.
- Figure 4. Assembly stacking sequence for the flat cell.
- Figure 5. Top of hermetically sealed flat cell showing G/M seal, nickel tab and fill tube.
- Figure 6. Photo of final version of flat cell with a vented cell.
- Figure 7. Performance of a fresh flat cell with new design on the GLLD test at room temperature.
- Figure 8. Performance of a fresh flat cell with new design on the GLLD test at room temperature.
- Figure 9. Performance of a fresh flat cell with old cell design on the GLLD test at room temperature.
- Figure 10. Performance of a flat cell with new design on GLLD test after 2.5 days at 72° C.
- Figure 11. Performance of a flat cell with new design on GLLD test at room temperature after 5 days at 72° C.
- Figure 12. Performance of a flat cell with new design on GLLD test at room temperature after 5 days at 72° C.

- Figure 13. Performance of a flat cell with new design on GLLD test at room temperature after 5 days at 72° C.
- Figure 14. Behavior of a flat cell during voltage reversal at 32A and 20A on the GLLD cycle.
- Figure 15. Behavior of a flat cell during voltage reversal at 3.2A and 20A on the GLLD cycle.
- Figure 16. Behavior of a flat cell during voltage reversal on GLLD at 3.2A and 20A on the GLLD cycle.
- Figure 17. Behavior of a flat cell during voltage reversal on GLLD at 3.2A and 20A on the GLLD cycle.
- Figure 18. Behavior of a flat cell during voltage reversal on GLLD at 3.2A and 20A on the GLLD cycle.
- Figure 19. Behavior of a lithium excess flat cell during voltage reversal on the GLLD loads of 3.2A and 20A.

I. Introduction

The Li/SOCl₂ inorganic electrolyte system (1-4) is the highest energy density system known to date. It consists of a Li anode, a carbon cathode and SOCl₂, which acts both as a solvent and cathode active material. The electrolyte salt that has been used most extensively is LiAlCl₄, but salts such as Li₂B₁₀Cl₁₀ (5) and Li₂O(AlCl₃)₂ (6) have also been used successfully in this system for improving the shelf life characteristics.

The main objective of this program is to develop high rate Li/SOCl₂ cells and batteries for portable applications of the U. S. Army. The cells and batteries must deliver higher energy densities than are presently available and must be safe to handle under field conditions.

We carried out a detailed development (7) on the spirally wound D cell in order to establish their performance capabilities and to identify limitations in their performance and safety under various use and abuse conditions. Substantial progress was made in the correction of cell limitations. We found that spirally wound D cells approached the high rate requirements of the various U. S. Army applications more closely than do any other cell designs at the present time. We used this spirally wound D cell as a starting point and improved its rate capability to meet the requirements of two specific applications, namely the BA5590 battery for manpack radio and the battery for the GLLD Laser Designator.

We concentrated our effort on the development of the high rate spirally wound D cell during the first two quarters to determine whether it was possible for the D cell to meet the performance requirements of the GLLD Laser Designator. The results obtained in the second quarter showed that the high rate D cells could deliver eighteen (18) bursts or 5.9 A.hr/cells compared to the three (3) bursts of 1A.hr/cell realized from the presently used Ni/Cd batteries. An advantage of the D cell over other cell geometries and configurations is that the D cell can be produced at our lithium battery manufacturing plant with

only slight modifications of the existing process which is used for manufacturing spirally wound Li/SO₂ D cells. The results were encouraging and we are continuing to improve the Li/SOCl₂ D cell so that it can meet a variety of high rate requirements, including the GLLD application.

During the third quarter we concentrated our effort on the development of the three inch diameter flat cylindrical cell for the GLLD Laser Designator Battery. We initiated procurement of parts during the first quarter. The detailed design of the flat cell and its parts, as well as the design and fabrication of tooling needed to make the parts and cell was mostly completed during the third quarter. We have developed two types of flat cell, one is 0.45 inch thick while the other is 0.90 inch thick. The packaging efficiency of the battery with 0.90 inch cells is substantially higher than with 0.45 inch cells. Construction and performance characteristics of both types of flat cells were described in the report for the third quarter.

During the first two quarters we also examined the cell reaction mechanism using cyclic voltammetry. The information gained from this study indicated several approaches for improving both performance and safety of Li/SOCl₂ cells. We evaluated the efficacy of these approaches during the third quarter and found that both performance and abuse resistance of the cells could be significantly improved by the use of additives. We evaluated some of the promising additives in the three inch diameter flat cell as well. During the fourth quarter we made additional engineering improvements to the 0.9 inch thick flat cell to enhance its performance. We found that the cell capacity and the abuse resistance of the D cell on the GLLD test were increased by the use of cathode additives. We also investigated the use of very long and thin electrodes to increase capacity on the GLLD test, with encouraging results.

During the fifth quarter we developed the D cell further with the aim of creating a cell design combining high capacity on the BA5590 test with the high rate performance necessary for GLLD test. This was done by increasing cathode capacity while maintaining a large electrode area. We also further defined the high rate performance of 0.9 inch flat cylindrical cell with impressive results.

In the sixth quarter we assembled and filled one hundred (100) cells of the D cell design selected for production during the fifth quarter. Storage life of the D cell was demonstrated by abusive storage at 72°C followed by GLLD and BA5590 tests. We further evaluated performance retention of the flat cell after storage and demonstrated the safety of the flat cell package during voltage reversal at 3.2A and 20A rates.

In the seventh quarter we have made several design changes to the electrode stacks of the flat cell primarily to improve the anode connections. Slight modifications of the can itself were also made so that the space inside the eight-cell battery package could be utilized more efficiently. We began to fabricate and stockpile all the parts needed for the assembly of about 60 cells. Forty cells will be delivered to the sponsor in the form of five 8 cell (in series) batteries. The remaining cells will be used in our laboratory to evaluate the performance of the final battery package under GLLD load. Due to the preparation of sizable amount of cell parts during this quarter, cell testing was limited to a few fresh and stored cells.

II. Laser Designator Battery

The specifications of the GLLD Laser Designator Battery are as follows:

Dimensions	2.82" x 3.75" x 9.30"
Voltage 24 nominal	
	Maximum (OCV) 32V
	Average 24V
	End 20V

We considered the following types of individual cells for the above battery:

- A. 16 spirally wound D cells; 8 in series, with the two series stacks in parallel.
- B. 16 flat cells (3 inch O.D., 0.45 inch thick); 8 in series with the two series stacks in parallel.
- C. 8 flat cells (3 inch O.D., 0.90 inch thick) in series.
- D. 8 cylindrical 1.8" diameter spirally wound cells in series.

The development of the D cells and the two types of flat cell were described in the six preceding reports (8-13). The original GLLD duty cycle was: 17.5A for 0.0355 sec followed by 1.8A for 0.0145 sec; this cycle continues for 3 minutes. This constitutes one burst. This three minute cycle occurs every thirty minutes. This duty cycle has been changed by the sponsor. The new duty cycle is 20A for 0.029 sec followed by 3.2A for 0.021 sec; this cycle continues for 20 seconds every three minutes. This duty cycle is shown schematically in Fig. 1. Cell capacities on the new and old GLLD regimes are very similar, while the shorter duration of the burst gives less cell heating with the new regime.

III. The Flat Cylindrical Cell

Introduction

We have developed the flat cylindrical cell, 3 inch in diameter and 0.9 inch thick, for the GLLD Laser Designator application. Fabrication of the cathodes and anodes are described in previous reports (9-11). Details of the construction of the final package are given below. The filled cell weighs approximately 225 gm. We optimized the internal electrode structures of this cell in order to obtain the best performance on GLLD load regime. The internal impedance of the cell was extremely low thus leading to a very low cell polarization and minimum cell heating on the GLLD load. The performance of the cell, as reported in the fourth quarterly report (11) was found to be outstanding. The cell delivered 300 pulses, corresponding to a capacity of 21 A.hr at room temperature.

During the fifth quarter we evaluated the behavior of the cylindrical flat cell at low temperatures. Its performance characteristics under voltage reversal, short circuit, and high current discharge conditions were also obtained. In the sixth quarter we evaluated the capacity retention of the above flat cell both at various temperatures after room temperature storage and at room temperature after abusive storage at 72°C. We also investigated high temperature (50°C) discharge of a flat cell on the GLLD duty cycle and the safety of the flat cell during voltage reversal on the GLLD test.

In the seventh quarter we made several design changes to improve the anode connections of the flat cell. We also fabricated sufficient parts to make at least forty cells which will be delivered in the form of five GLLD batteries to the sponsor upon completion of this program. Each battery will contain eight flat cylindrical cells connected in series as shown schematically in Figure 2. We also continued cell performance testing using both fresh and stored cells during this quarter.

Experimental

We have made several design changes to the electrode stack of the flat cylindrical cell in order to improve the anode connections. The original design has been described in detail elsewhere (10). This final version differs from the "old" design in several ways. The anodes are now clamped against a solid stainless steel centerpost which has a solid stainless steel washer at the top and is threaded at the bottom. A tantalum tab is welded to this post. An exmet washer located at the top of the electrode stack is then welded to this tantalum tab. This exmet washer, as has been described in our previous reports, is buried in the top anode of the cell to complete the electrical contact between the anode and the centerpost. This arrangement is further illustrated in Figure 3. An identical piece of tantalum tab is also welded to the centerpost on the opposite side with the same exmet washer welded to it.

The sequence adopted to stack the electrodes in the flat cell is shown in Figure 4. In this final version an additional lithium washer is placed under each exmet washer to act as a spacer. Without these spacers, the electrode stack tended to become distorted during the assembly process.

Another design change involves the can itself. Originally, the centerpost of the can protruded approximately 1/8" above the glass-to-metal seal in the top half of the can. This post is now flush with the top of the G/M seal as shown in Figure 5. A nickel tab welded to the end of the post is used as the negative terminal. This change was made to better utilize the space available in the eight cell battery package.

Initially, a glass-to-metal vent was built into the bottom half of the can. This vent was eliminated due to the unsatisfactory performance of such a design. The G/M seal at the top half of the can was found to be a reliable vent capable of withstanding pressures up to about 200 psig. A photograph of the final version flat cell together with a vented cell is included in this report as Figure 6.

Discharge performance characteristics of both fresh and stored cells were obtained using procedures described for the high rate D cell tests (12).

Results and Discussion

The voltage-time curve of two fresh flat cells built with the newly developed anode connections on GLLD duty cycles are shown in Figures 7 and 8. These cells were filled with 1.8M $\text{LiAlCl}_4/\text{SOCl}_2$. They were found to be capable of delivering 12.4 and 10.8 A.hrs to a 2.5V cutoff, respectively. Cell pressure rose to 40-50 psig during the discharge. Temperature of the cell was found to rise to $\sim 40^\circ\text{C}$. The second cell (Figure 8) did not perform as well as the first one (Figure 7) probably due to internal self-discharge because the cell was found to become warm during filling. Both cells showed a voltage tail at 20A in contrast to a sharp voltage drop, characteristic of Li/SOCl_2 cells.

These rate capabilities are significantly lower than the ones obtained previously in this program with cells of the original design. Some of those cells were capable of delivering up to 21 A.hrs on GLLD load. Therefore, we constructed and tested another cell of the original design and the result is shown in Figure 9. This "old" cell delivered 13.2 A.hrs on GLLD which is not too different from the performance of the two cells reported above. Based on these results, we concluded that the new design changes most probably did not cause the flat cell to lose its rate capability. We are reasonably confident that the new anode connections are far more superior than the original design. The decrease in rate capability must be caused by a source other than the design changes made recently. Efforts will be made, to the extent allowable without affecting the delivery schedule, to first identify and then resolve this problem in order to bring the high rate capacity of the flat cell back to 20 A.hrs.

A number of cells were placed on abusive storage at 72°C . These cells were then tested at room temperature on GLLD duty cycles. They all showed a decrease in capacity to 2.5V and an increased capacity between 2.5V to 2.0V when compared to the performance of the fresh cells. Figure 10 shows a voltage-time curve of a cell stored at 72°C for 2-1/2 days. It delivered 8.5 A.hrs to

2.5V and 14.6 A.hrs to 2.0V. Once again, a voltage "tail" similar to the ones observed in fresh tests is present at 20A rate. The temperature of this cell reached 50°C during discharge which is 10°C higher than what we observed with a fresh cell (Figure 7).

Three other cells stored at 72°C for 5 days were found to deliver 7.4, 6.2, and 9.9 A.hrs, respectively, to a 2.5V cutoff voltage (Figures 11-13). These cells were also capable of delivering large capacities between 2.5 to 2.0V with apparent voltage tails. The capacities of these cells to 0V is almost the same as that of a fresh cell. This indicates that the coulombic capacity remained unchanged after abusive storage at 72°C.

We further investigated the safety of the flat cylindrical cell during GLLD voltage reversal. It has been established that a proper excess of lithium in the cell will greatly enhance the safety of the cell during voltage reversal. Figures 14 and 15 showed the voltage-time curves of two flat cells each originally contained 25 A.hrs of lithium. Both cells vented through the G/M seal with pressures exceeding 170 psig during voltage reversal on GLLD load. The voltage was near 0.0V at 3.2A and -0.75V at 20A when venting occurred. During reversal a vented can showed a 0.2 inch increase in can thickness due to bulging. A photograph of a vented cell is shown in Figure 6.

Three other cells originally containing 25-27 A.hrs of lithium did not vent during GLLD voltage reversal tests. The results are shown in Figures 16-18. They all show the characteristic voltage clamping of the flat cell during reversal. Cell temperature peaked at ~65°C and then equilibrated at ~30°C. Pressure of the cell was found to reach as high as 125 psig during the peak under voltage reversal and finally decreased to the 20-30 psig range.

The voltage reversal test was also carried out using a cell with a large excess of lithium (41 A.hrs) and the result is shown in Figure 19. The cell was driven deep into voltage reversal and only very temporary and modest pressure build-up and temperature increase were recorded. Voltage was found to be clamped at 0.0V at 3.2A and -0.25V at 20A, respectively, for up to 17 hours. The large excess of lithium seemed to insure a safe, uneventful voltage reversal over an indefinite period.

IV. Conclusion

During the seventh quarter of this contract we have fabricated enough parts to assemble all the flat cylindrical cells needed for the final delivery to the sponsor and the performance evaluation tests in our laboratory.

Several design changes were made to improve the anode connections to the negative terminal post inside the cell. Modifications were also made to the can itself for safety and packaging considerations.

Unfortunately, we discovered that the rate capability of the flat cells built during this quarter are significantly lower than that of the cells we built earlier in this program. It has also been established that this loss in cell capacity is most probably not caused by the recent design changes. Efforts will be made to resolve this problem in the next quarter.

The loss in cell capacity after abusive storage has once again been found to be significant. We have also re-established the safety of the flat cell configuration against venting or explosion provided that proper materials loadings are strictly obeyed in the cell.

V. References

1. W. K. Behl, J.A. Cristopulos, M. Ramirez and S. Gilman, *J. Electrochem. Soc.*, 120, 1619 (1973).
2. J. J. Auburn, K. W. French, S. I. Lieberman, V. K. Shah and A. Heller, *ibid*, 120, 1613 (1973).
3. D. L. Maricle et al, U. S. Pat. 3, 567, 515 (1971); G. E. Blomgren and M. L. Kronenberg, German Pat. 2, 262, 256 (1973).
4. A. N. Dey and C. R. Schlaikjer, Proc. 26th Power Sources Symposium, Atlantic City, April 1974.
5. C. R. Schlaikjer, U. S. Pat. 4, 020, 240 (1977), Proc. 28th Power Sources Symposium, Atlantic City, June 1978.
6. J. P. Gabano and P. Lenfant, Abstract No. 27, Electrochemical Society Meeting, Pittsburg, PA , Oct. 1978.
7. A. N. Dey, "Sealed Primary Lithium Inorganic Electrolyte Cell" Final Report, DELET-TR-74-0109-F, P. R. Mallory & Co., Inc. July 1978.
8. A. N. Dey, W. Bowden, J. Miller, P. Witalis, "Lithium-Thionyl Chloride Battery", ERADCOM, DELET-TR-79-0563-1, First Quarterly Report, P. R. Mallory & Co. Inc., April, 1979.
9. A. N. Dey, W. Bowden, J. Miller, P. Witalis, "Lithium-Thionyl Chloride Battery", ERADCOM, DELET-TR-78-0563-2, Second Quarterly Report, P. R. Mallory & Co. Inc., July, 1979.
10. A. N. Dey, N. Hamilton, W. Bowden, P. Witalis, "Lithium-Thionyl Chloride Battery", ERADCOM, DELET-TR-78-0563-3, Third Quarterly Report, P. R. Mallory & Co. Inc., July, 1979.

11. A. N. Dey, N. Hamilton, W. Bowden, P. Witalis, D. Cubbison, "Lithium-Thionyl Chloride Battery", ERADCOM, DELET-TR-79-0563-4, Third Quarterly Report, P. R. Mallory & Co. Inc., February, 1980.
12. A. N. Dey, N. Hamilton, W. Bowden, P. Witalis, D. Cubbison, "Lithium-Thionyl Chloride Battery", ERADCOM, DELET-TR-78-0563-5, Fifth Quarterly Report, Duracell International Inc., June, 1980.
13. A. N. Dey, N. Hamilton, W. Bowden, P. Witalis, D. Cubbison, "Lithium-Thionyl Chloride Battery", ERADCOM, DELET-TR-78-0563-6, Sixth Quarterly Report, Duracell International Inc., September, 1980.

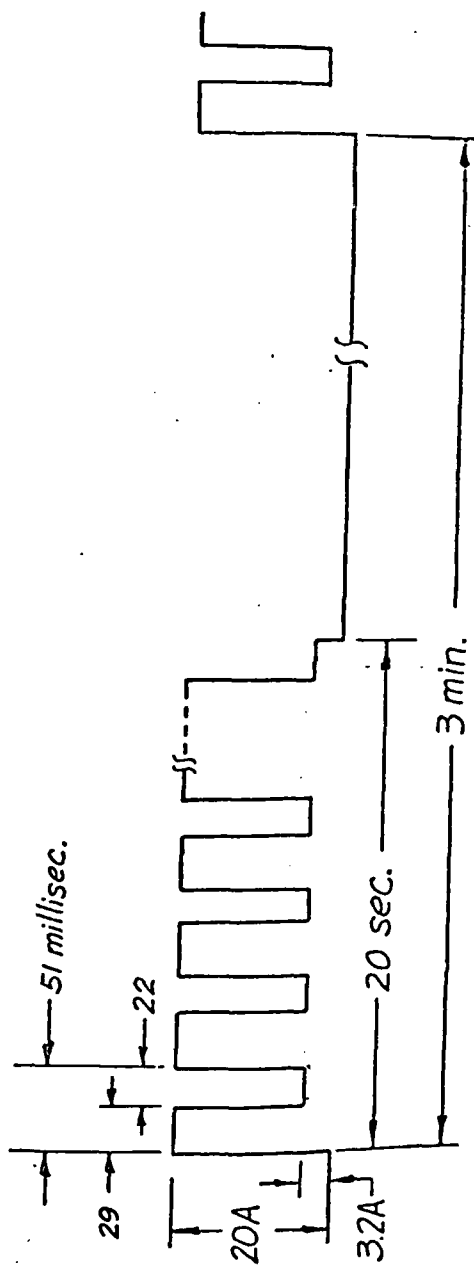

Fig. 1. Schematic diagram for the pulse discharge in the new GLLD duty cycle

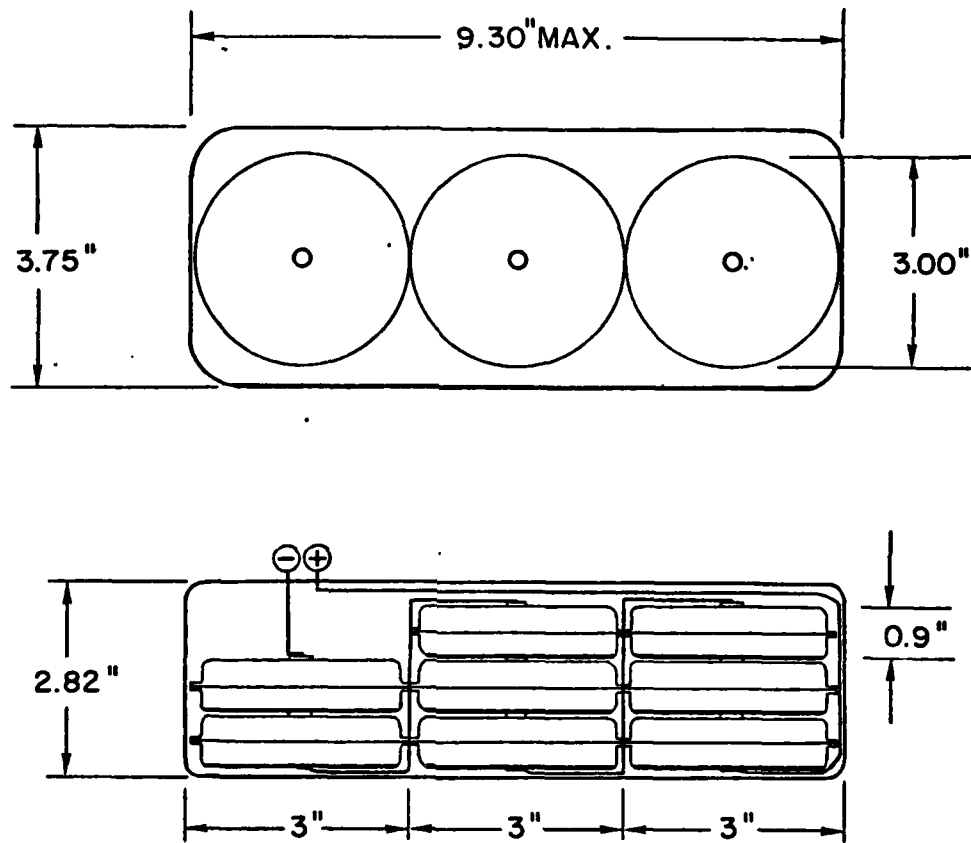

Fig. 2

Schematic outline for the GLLD battery using 8 x 3" O. D.,
0.90" thick flat cells.

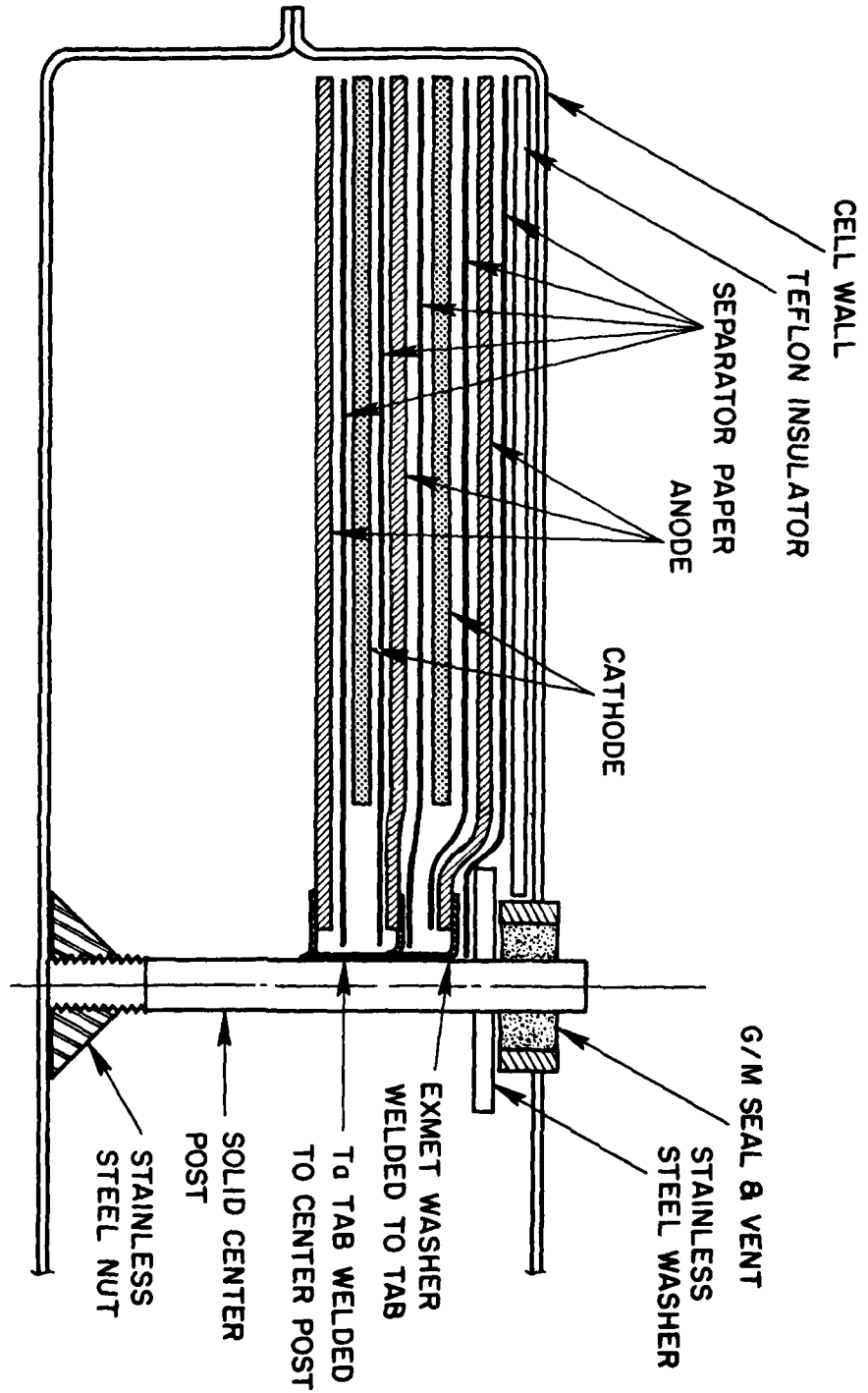

Fig. 3. Lithium anode contact detail of finalized version of the flat cell.

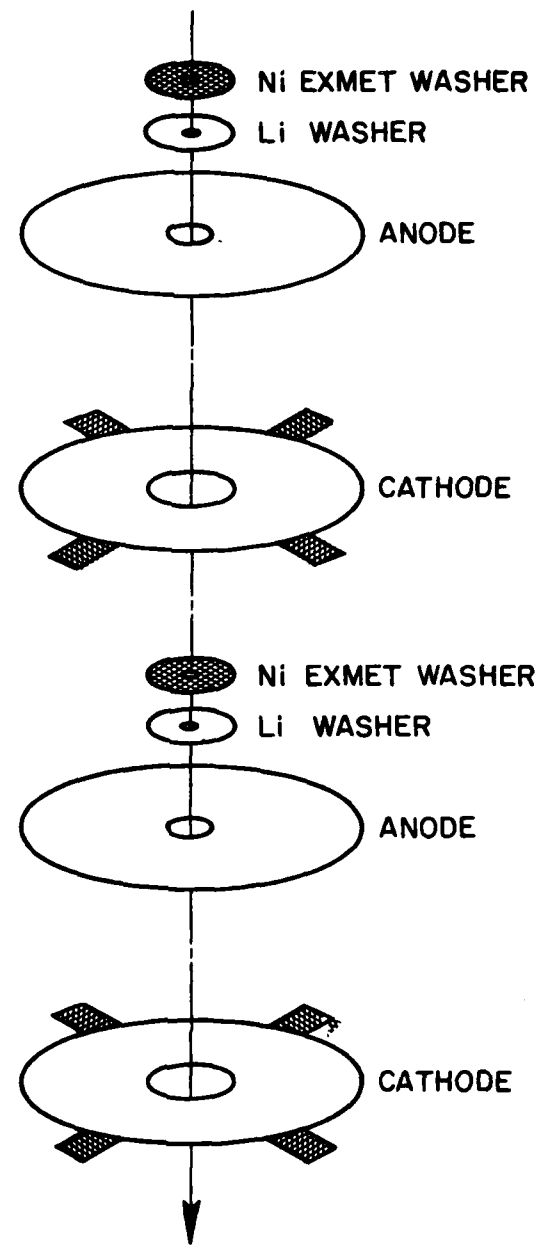

Fig. 4. Assembly stacking sequence for the flat cell.

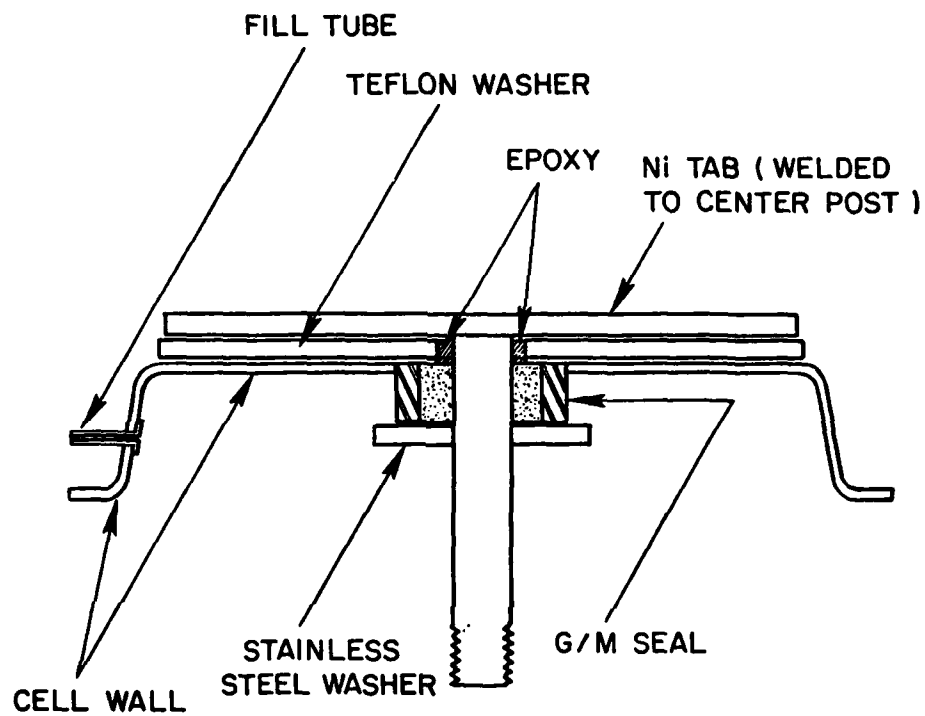

Fig. 5. Top of hermetically sealed flat cell showing G/M seal, nickel tab and fill tube.

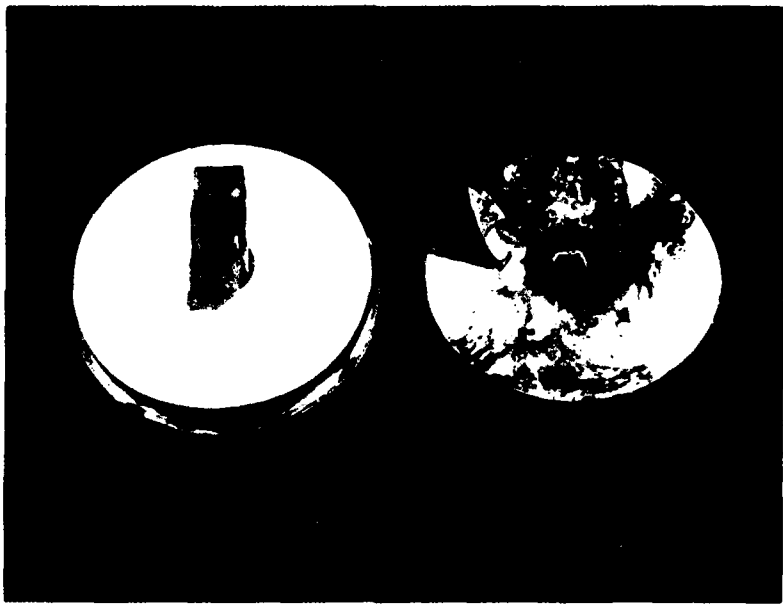

Fig. 6. Photo of final version of flat cell with a vented cell.

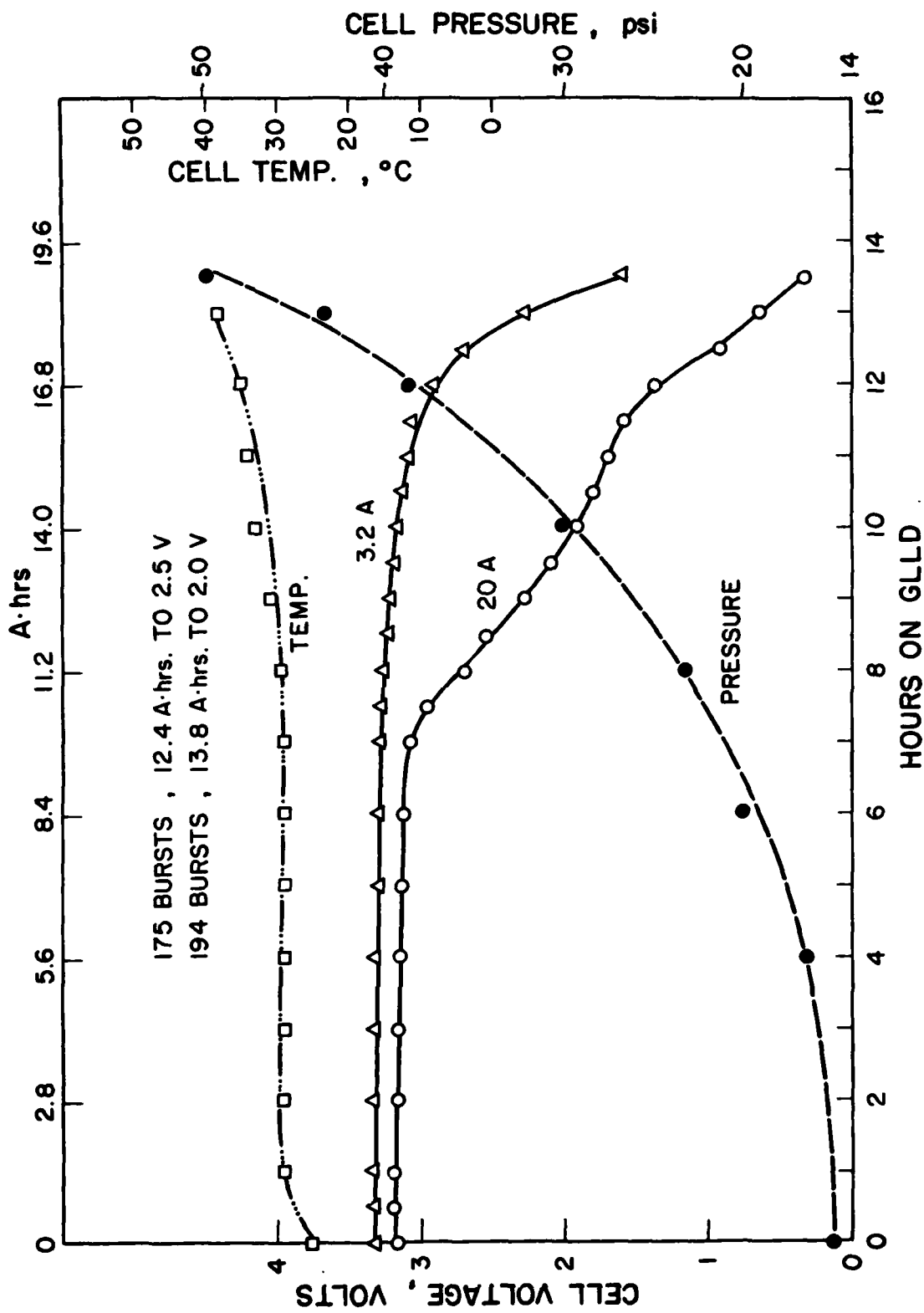

Fig. 7. Performance of a fresh flat cell with new design on the GLLD test at room temperature.

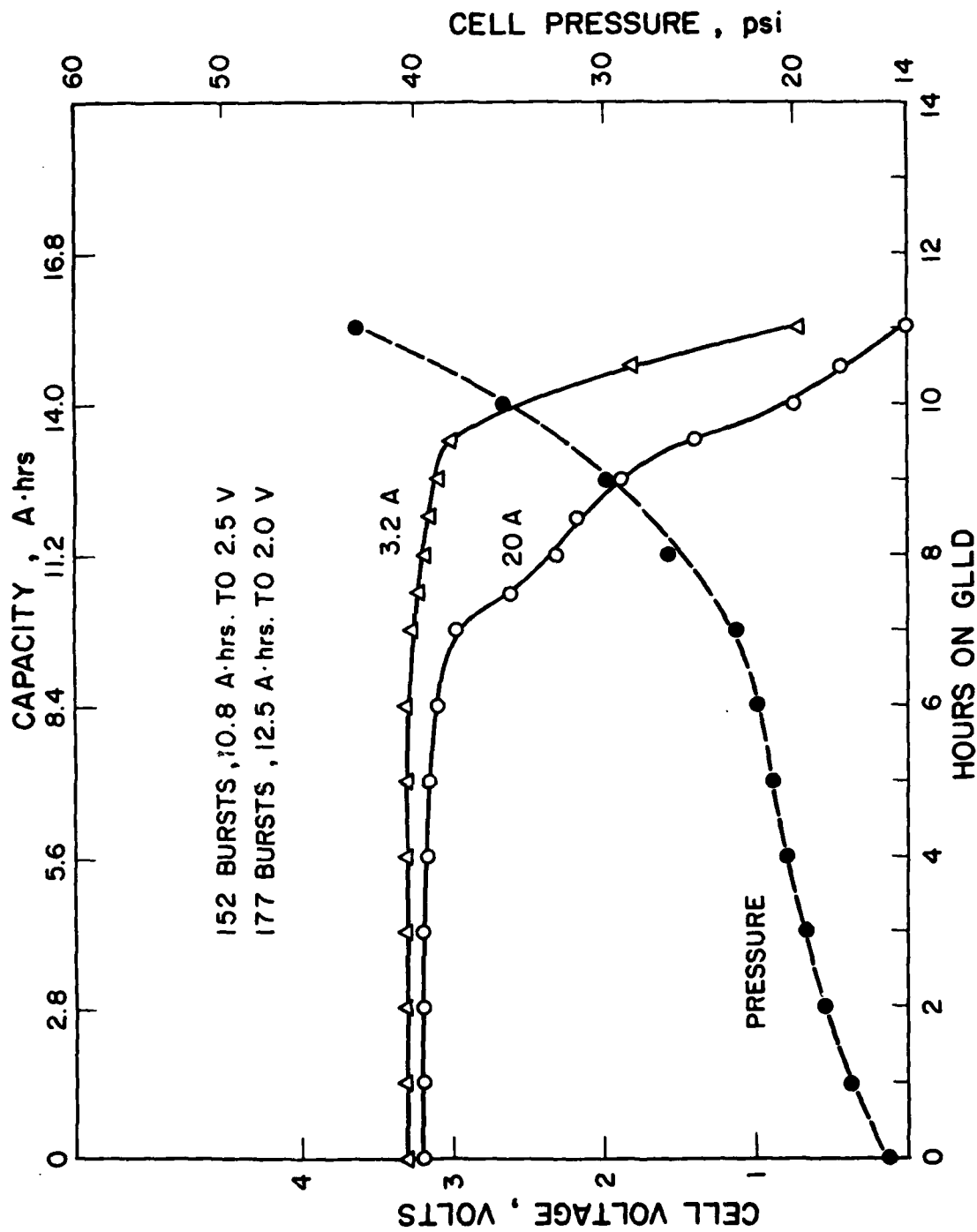

Fig. 8. Performance of a fresh flat cell with new design on the GLLD test at room temperature.

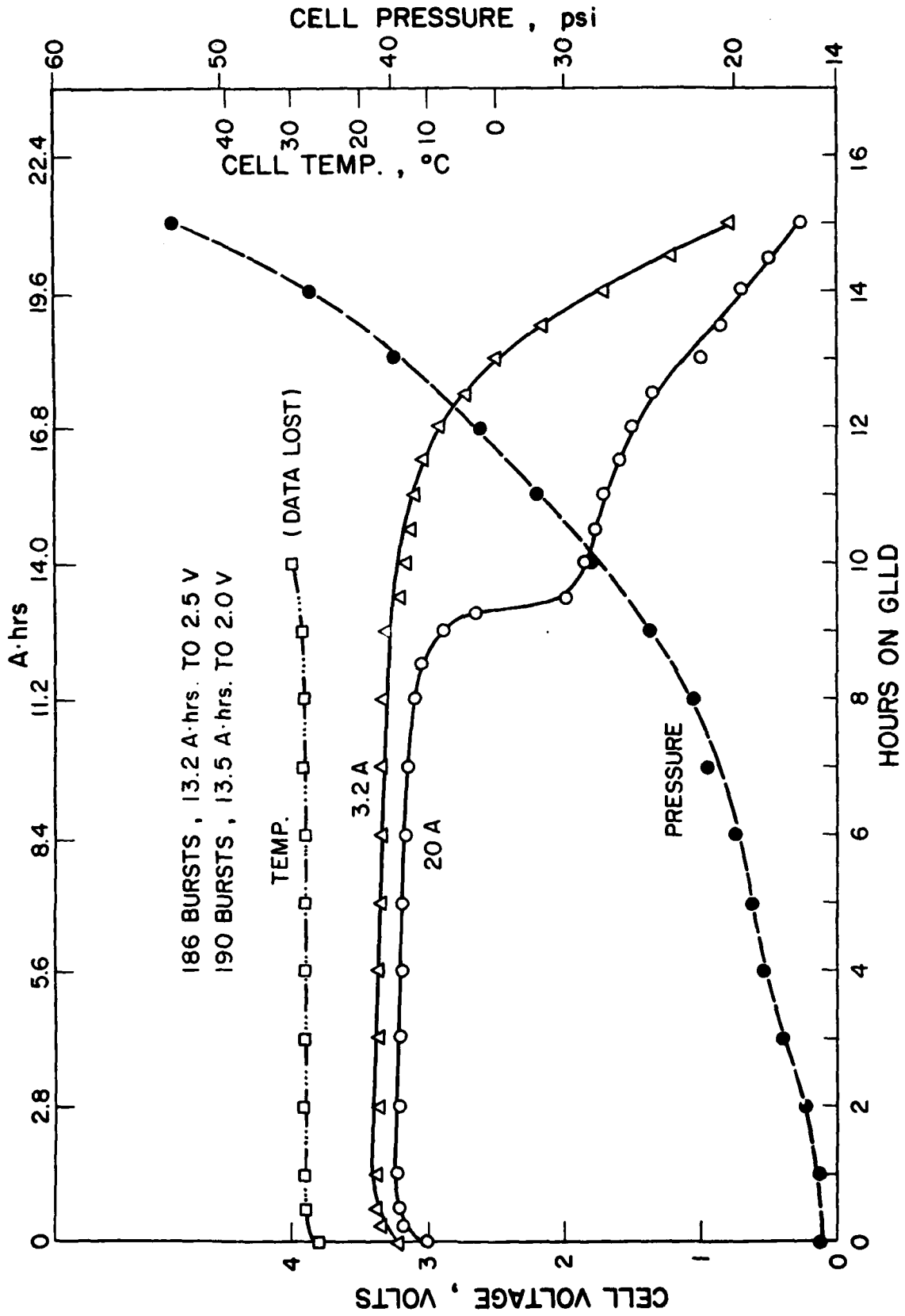

Fig. 9. Performance of a fresh flat cell with old cell design on the GLLD test at room temperature.

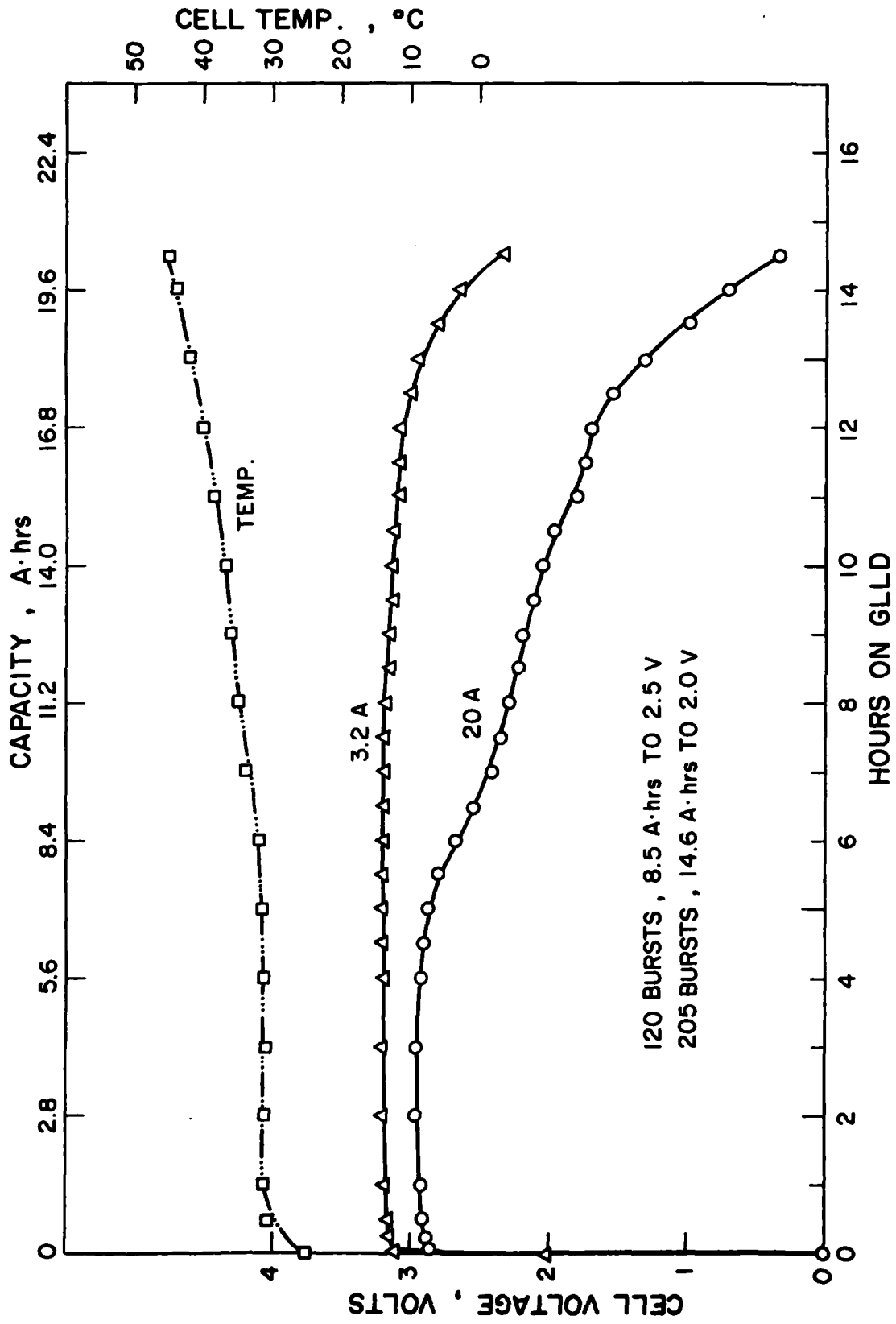

Fig. 10. Performance of a flat cell with new design on GLLD test after 2.5 days at 72°C.

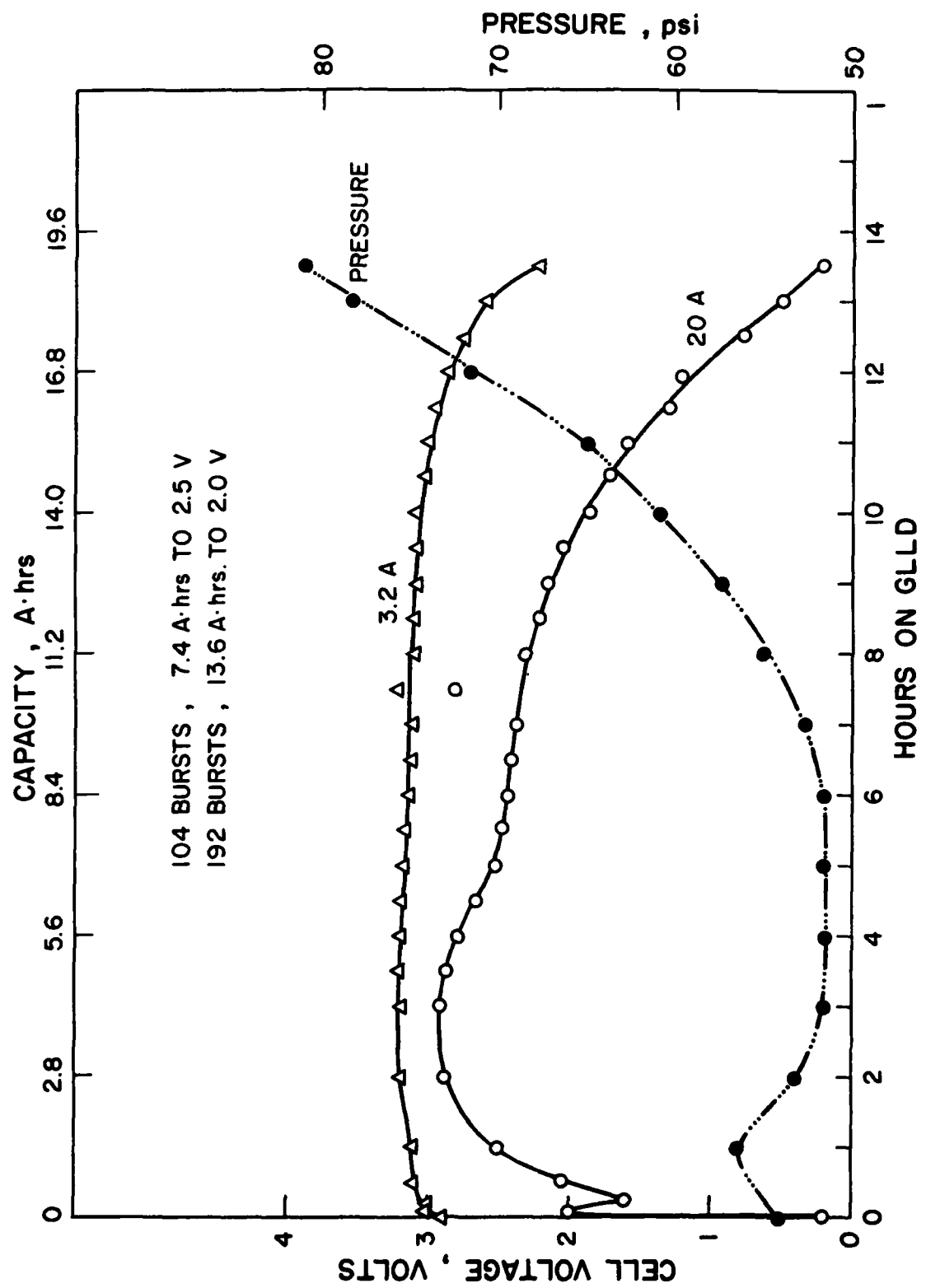

Fig. 11. Performance of a flat cell with new design on GLLD test at room temperature after 5 days at 72°C.

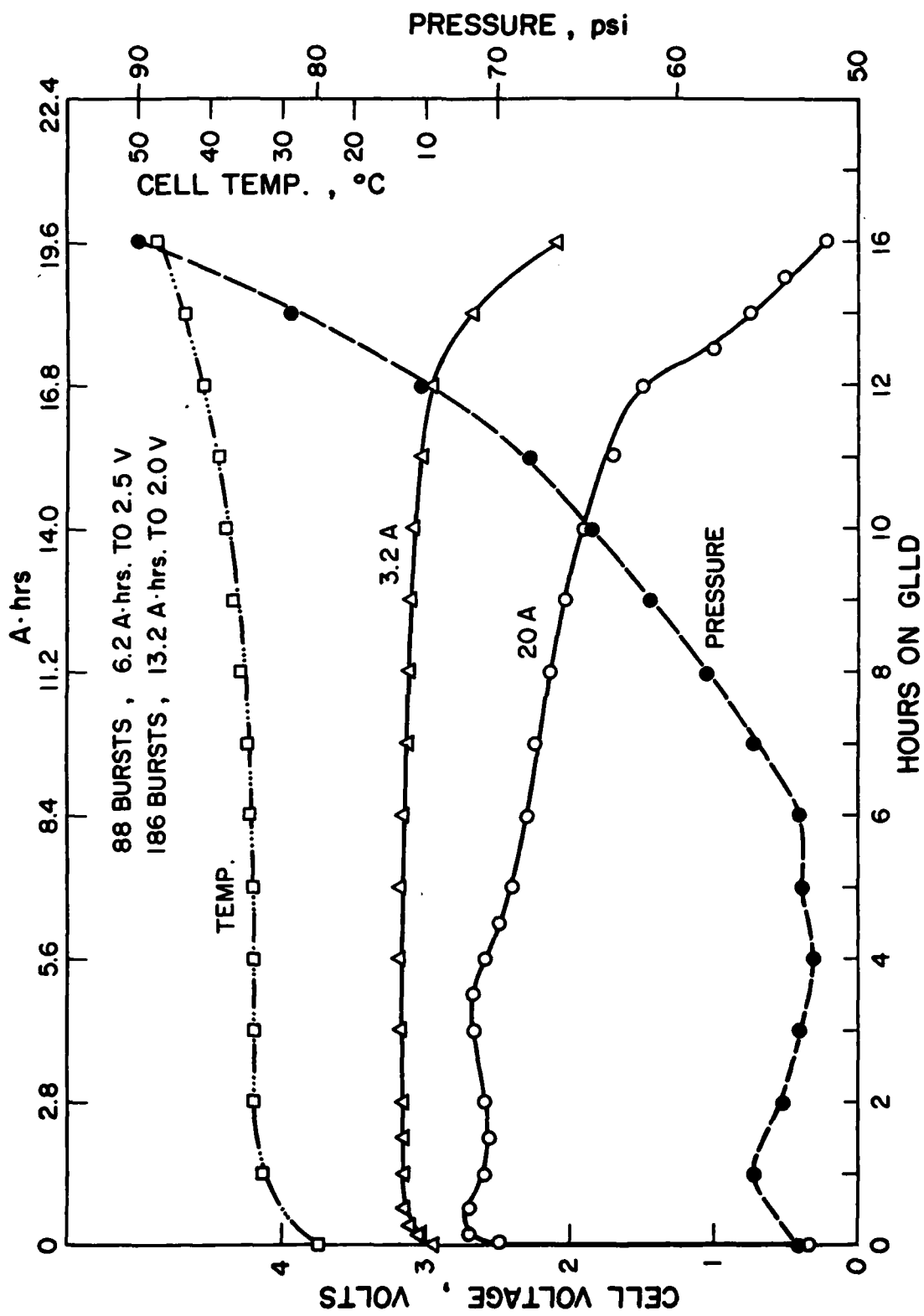

Fig. 12. Performance of a flat cell with new design on GLLD test at room temperature after 5 days at 72°C.

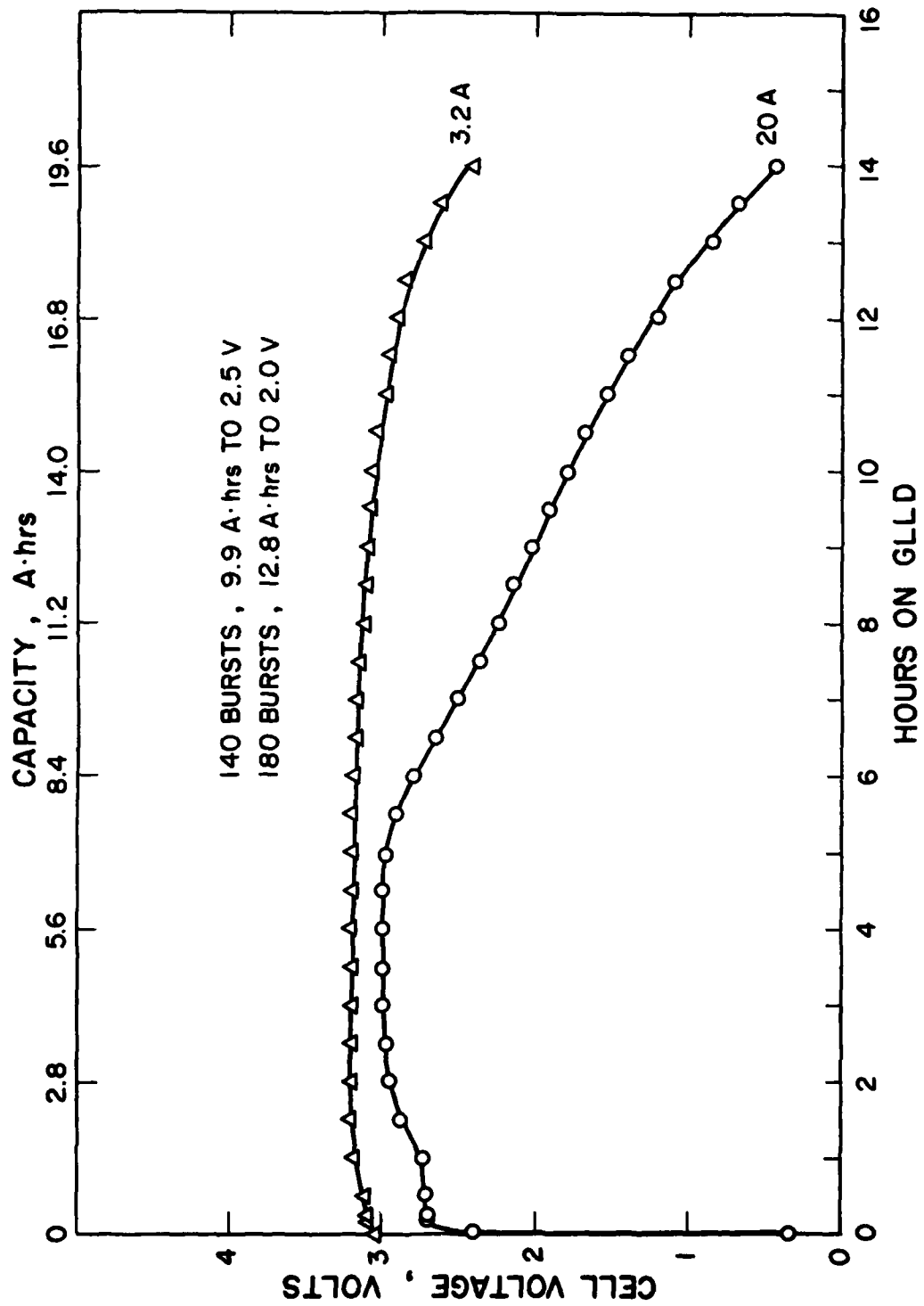

Fig. 13. Performance of a flat cell with new design on GLLD test at room temperature after 5 days at 72°C.

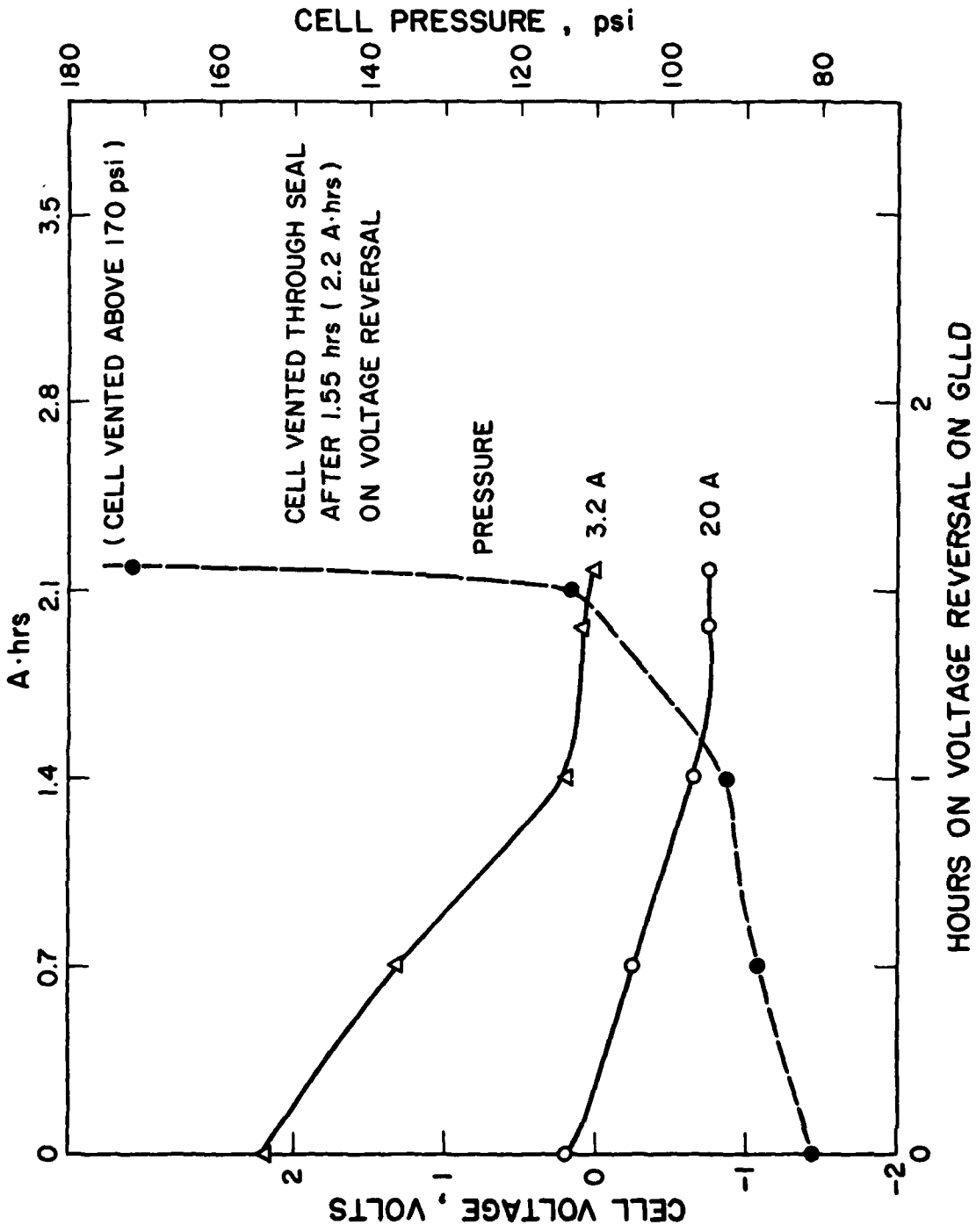

Fig. 14. Behavior of a flat cell during voltage reversal at 32A and 20A on the GLLD cycle.

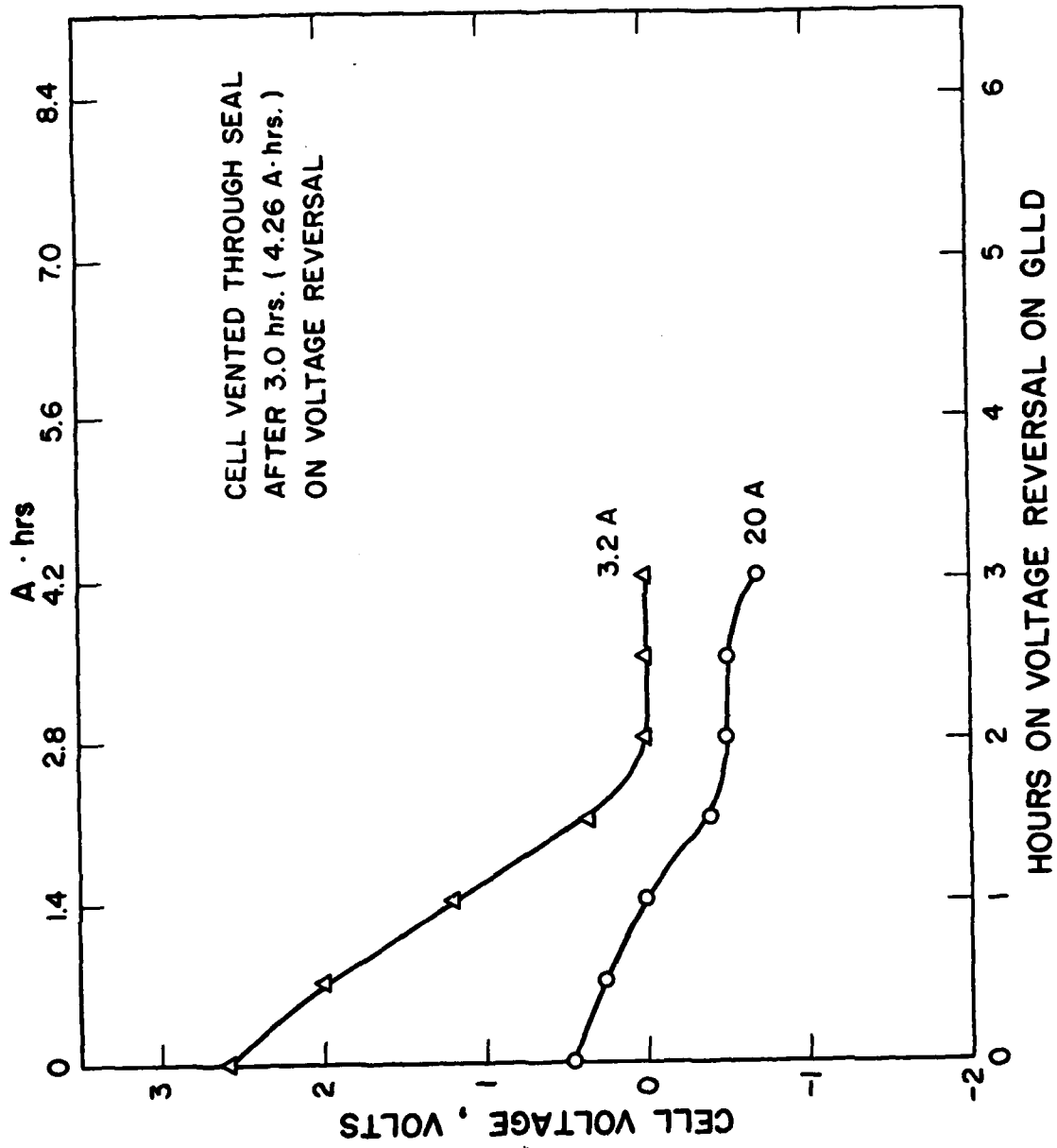

Fig. 15. Behavior of a flat cell during voltage reversal at 3.2 A and 20 A on the GLLD cycle.

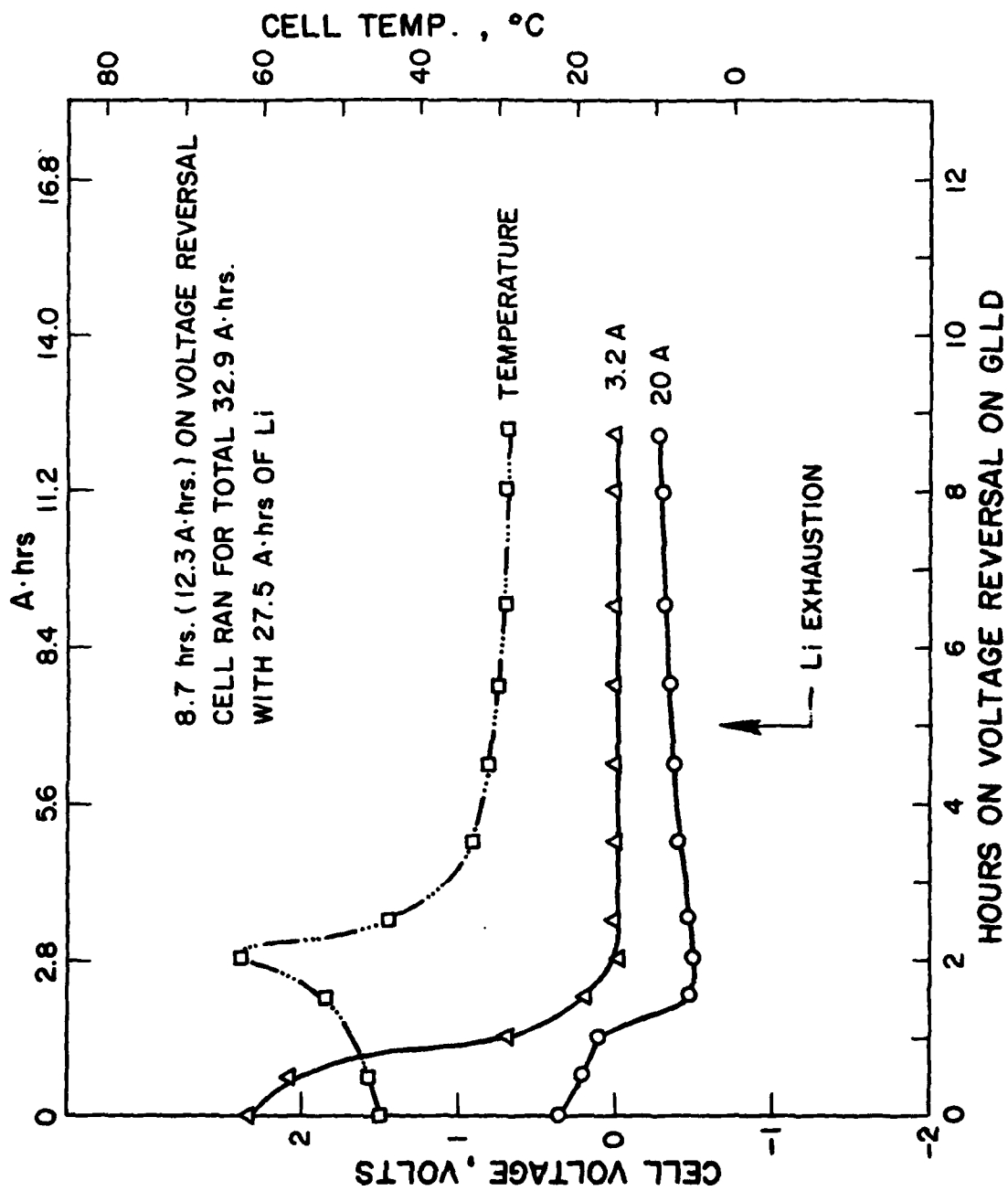

Fig. 16. Behavior of a flat cell during voltage reversal on GLLD at 3.2A and 20A on the GLLD cycle.

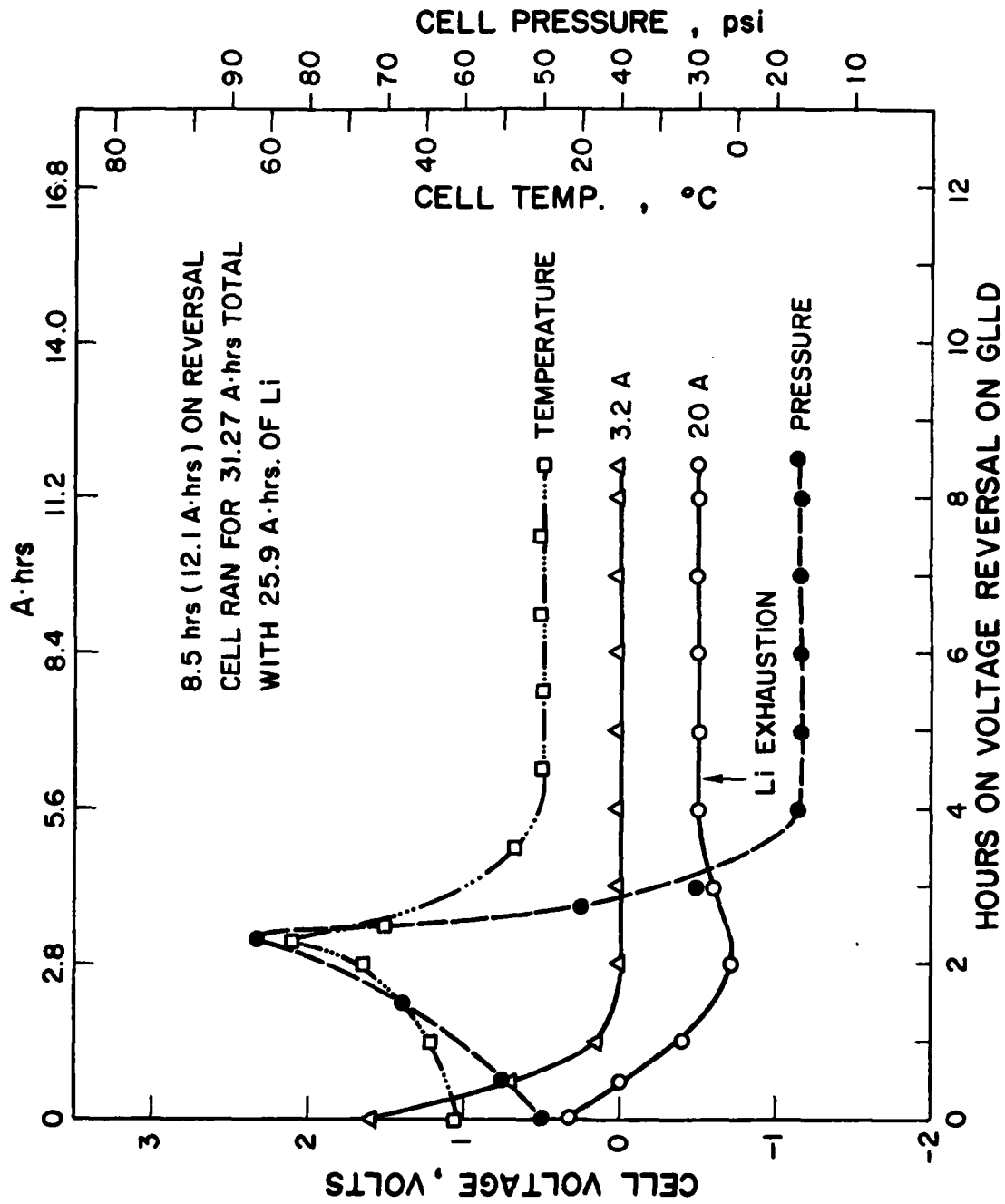

Fig. 17. Behavior of a flat cell during voltage reversal on GLLD at 3.2A and 20A on the GLLD cycle.

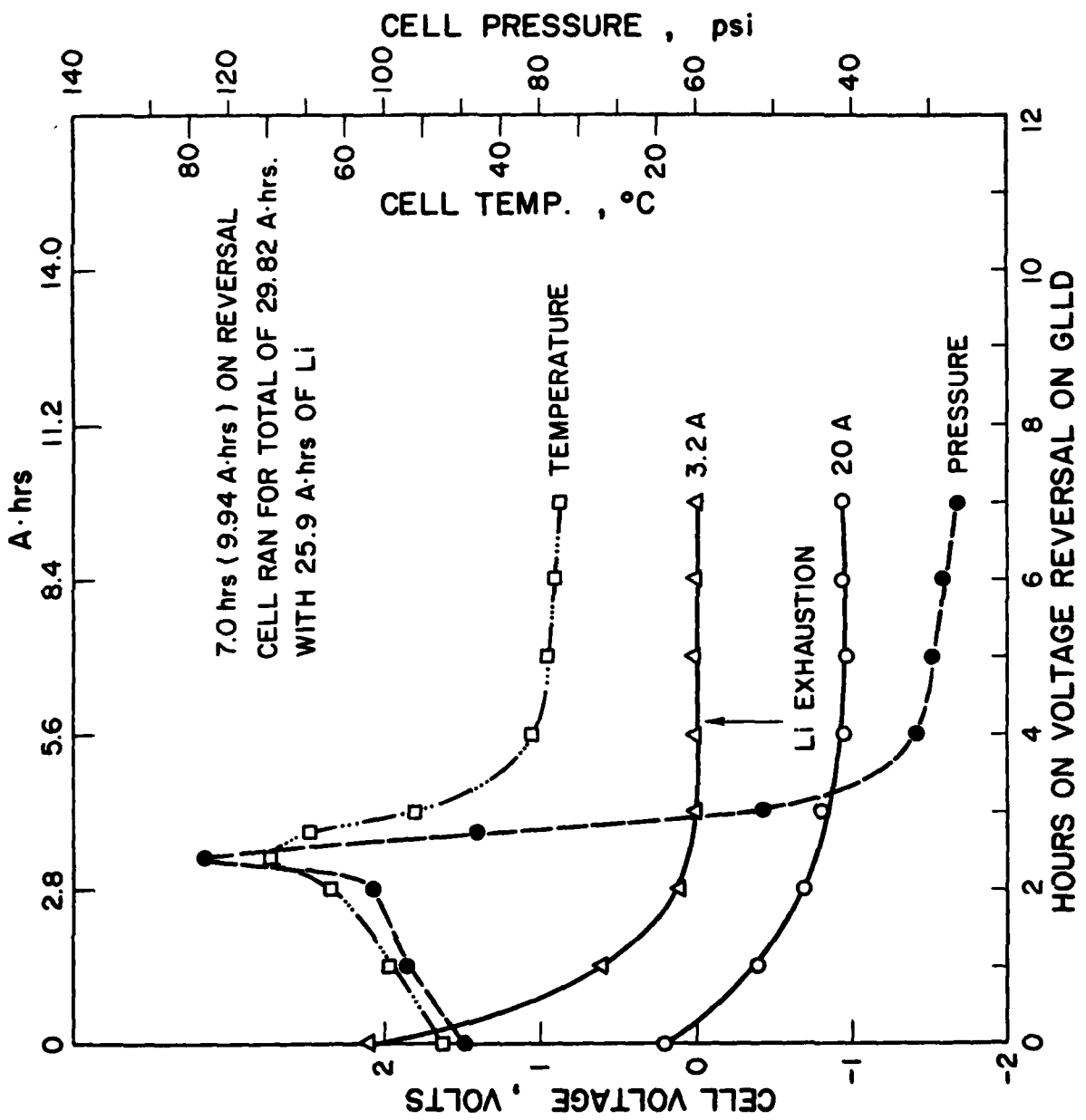

Fig. 18. Behavior of a flat cell during voltage reversal on GLLD at 3.2A and 20A on the GLLD cycle.

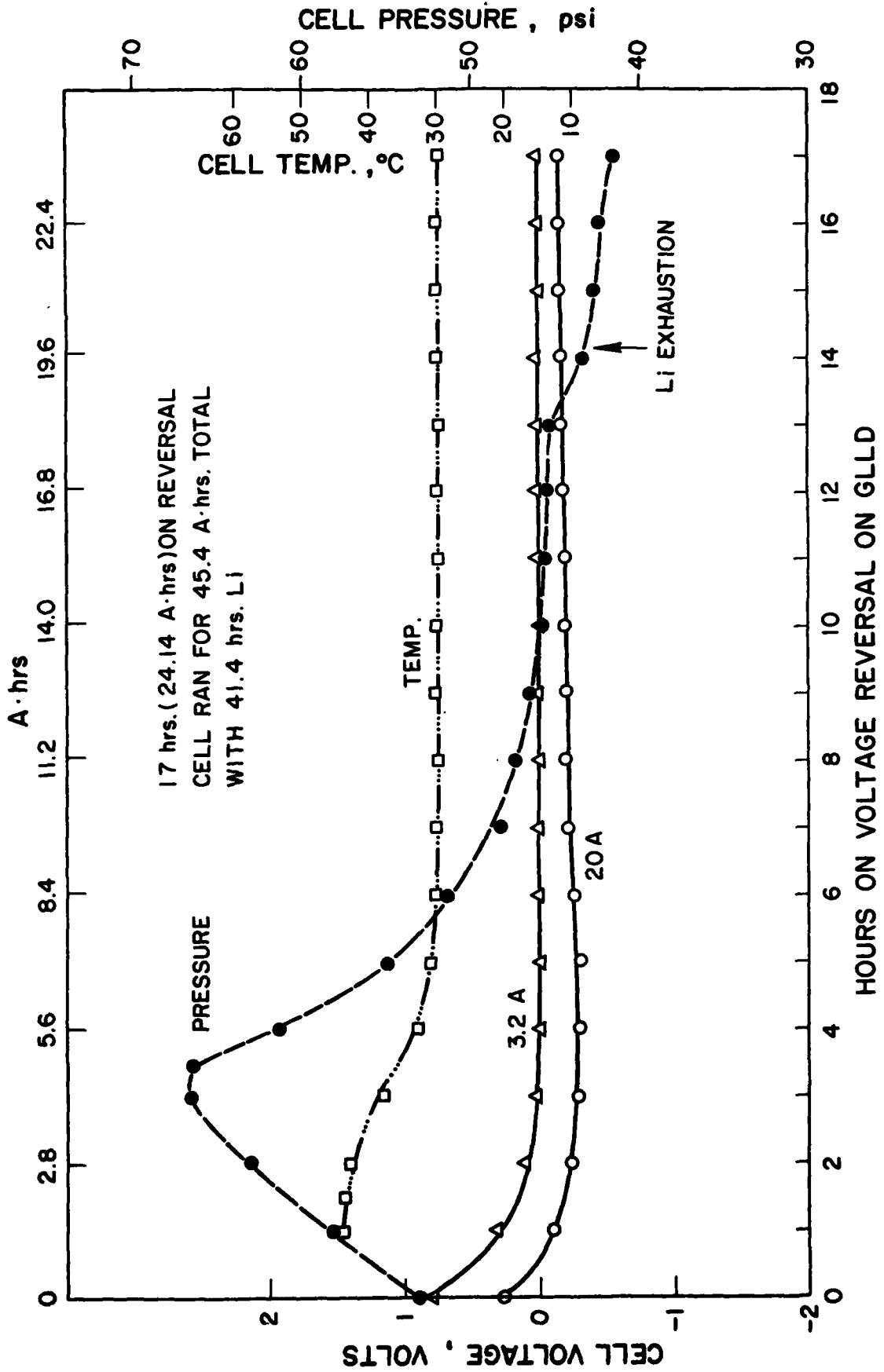

Fig. 19. Behavior of a lithium excess flat cell during voltage reversal on the GLLD loads of 3.2A and 20A.

13 November 1979

ELECTRONICS TECHNOLOGY AND DEVICES LABORATORY

MANDATORY CONTRACT DISTRIBUTION LIST

101	Defense Technical Information Center ATTN: DTIC-TCA Cameron Station (Bldg 5) Alexandria, VA 22314	579	Cdr, PM Concept Analysis Centers ATTN: DRCPH-CAC Arlington Hall Station Arlington, VA 22212
012		001	
203	GIDEP Engineering & Support Dept TE Section PO Box 398 NORCO, CA 91760	602	Cdr, Night Vision & Electro-Optics ERADCOM ATTN: DELNV-D Fort Belvoir, VA 22060
001		001	
205	Director Naval Research Laboratory ATTN: CODE 2627 Washington, DC 20375	603	Cdr, Atmospheric Sciences Lab ERADCOM ATTN: DELAS-SY-S White Sands Missile Range, NM 880
001		001	
301	Rome Air Development Center ATTN: Documents Library (TILD) Griffiss AFB, NY 13441	607	Cdr, Harry Diamond Laboratories ATTN: DELHD-CO, TD (In Turn) 2800 Powder Mill Road Adelphi, MD 20783
001		001	
437	Deputy for Science & Technology Office, Asst Sec Army (R&D) Washington, DC 20310	609	Cdr, ERADCOM ATTN: DRDEL-CG, CD, CS (In Turn) 2800 Powder Mill Road Adelphi, MD 20783
001		001	
438	HQDA (DAMA-ARZ-D/Dr. F. D. Verderame) Washington, DC 20310	612	Cdr, ERADCOM ATTN: DRDEL-CT 2800 Powder Mill Road Adelphi, MD 20783
001		001	
482	Director US Army Materiel Systems Analysis Actv ATTN: DRXSY-T Aberdeen Proving Ground, MD 21005	680	Commander US Army Electronics R&D Command Fort Monmouth, NJ 07703
001		000	
563	Commander, DARCOM ATTN: DRCDE 5001 Eisenhower Avenue Alexandria, VA 22333	1	DELET-P
001		1	DELEW-D
564	Cdr, US Army Signals Warfare Lab ATTN: DELSW-OS Vint Hill Farms Station Warrenton, VA 22186	1.	DELET-DD
001		1	DELSL-L (Tech Library)
		2	DELSL-L-S (STINFO) Originating Office
		(2)	DELET-PR (Gilman)
		681	Commander US Army Communications R&D Command ATTN: USMC-LHO Fort Monmouth, NJ 07703
		001	
		705	Advisory Group on Electron Devices 201 Varick Street, 9th Floor New York, NY 10014
		002	

1

CMDR, MICOM ATTN: DRCPM-HDE Redstone Arsenal, AL 35809	(1)	General Motors Corp. Research Laboratories General Motors Technical Center 12 Mile and Mounds Roads Warren, MI 48090 ATTN: Dr. J.L. Hartman	(1)
Transportation Systems Center Kendall Square Cambridge, MA 02142 ATTN: Dr. Norman Rosenberg	(1)	Union Carbide Corporation Parma Research Center P.O. Box 6116 Cleveland, OH 44101	(1)
Foote Mineral Company Route 100 Exton, PA 19341 ATTN: Dr. H. Grady	(1)	P.R. Mallory & Co., Inc. S. Broadway Tarrytown, NY 10591 ATTN: J. Dalfonso	(1)
Honeywell, Inc. 104 Rock Road Horsham, PA 19044	(1)	North American Rockwell Corp. Atomics Internation Division Box 309 Canoga Park, CA 91304 ATTN: Dr. L. Heredy	(1)
Sanders Associates, Inc. Sonobuoy Division 95 Canal Street Nashua, N.H. 03060	(1)	General Electric Research & Development Center P.O. Box 8 Schenectady, NY 12301 ATTN: Dr. Stefan Mitoff	(1)
Eagle-Picher Industries, Inc. Electronics Division P.O. Box 47 Joplin, Missouri 64801 ATTN: Mr. Robert L. Higgins	(1)	University of California Department of Science & Research Santa Barbara, CA 93100 ATTN: Dr. J. Kennedy	(1)
Yardney Electric Company 82 Mechanic Street Pawcatuck, CT 06379 ATTN: Technical Library	(1)	Gulton Industries, Inc. Metuchen, NJ 08840 ATTN: Mr. S. Charlip	(1)
Exxon Research & Engineering Co. Corporate Research Laboratory Linden, NJ 07036 ATTN: Dr. R. Hamlen	(1)	INCO Research and Development Center Sterling Forest Suffern, NY 10901 ATTN: Nehemiah Margalit	(1)
Argonne National Laboratories 9700 South Cass Argonne, IL 60439 ATTN: Dr. E.C. Gay	(1)	Director Propulsion and Power Division Mail Code EP5 NASA-Johnson Space Center Houston, Texas 77058 ATTN: Mr. B.J. Bragg	(1)
GTE Sylvania, Inc. 77 A Street Needham Heights, MA 02194 ATTN: Mr. Richard Pabst	(1)	GTE Laboratories, Inc. 520 Winter Street Waltham, MA 02154 ATTN: Dr. Ronald McDonald	(1)
Tufts University Department of Chemistry Medford, MA 02155	(1)		

Distribution List - Continued

Electrochimica 2485 Charleston Road Mountain View, CA 94040 ATTN: Dr. Eisenberg	(1)	Energy Conversion Branch Code 3642 Naval Underwater Systems Center Newport Laboratory Newport, RI 02840 ATTN: Mr. J.R. Moden	(1)
Dr. Hugh Barger P.O. Box 2232 Davidson, NC 28036	(1)	NASA Lewis Research Center Mail Stop 6-1 21000 Brookpark Road Cleveland, OH 44135 ATTN: Dr. Stuart Fordyce	(1)
Energy Storage & Conversion Dept. TRW Systems One Space Park Redondo Beach, CA 90278 ATTN: Dr. H.P. Silverman	(1)	Naval Undersea Center Code 608 San Diego, CA 92132 ATTN: Mr. Joe McCartney	(1)
Sanders Associates, Inc. 24 Simon Street Mail Stop NSI-2208 Nashua, NH 03060 ATTN: J. Marshall	(1)	EIC, Inc. Newton, MA 02158 ATTN: S.B. Brummer	(1)
Power Conversion, Inc. 70 MacQuesten Pkwy Mount Vernon, NY 10550 ATTN: Stuart Chodosh	(1)	Altus Corp. 440 Page Mill Road Palo Alto, CA 94306 ATTN: Douglas Glader	(1)
Portfolio Manager Hooker Chemicals & Plastics Corp. M.P.O. Box 8 Niagara Falls, NY 14302	(1)	MS 488 NASA Langley Research Center Hampton, VA 23665 ATTN: J. Bene	(1)
G207 S.R.I. Menlo Park, CA 94025 ATTN: Dr. Leonard Nanis	(1)	Research and Development Division The Gates Rubber Co. 999 S. Broadway Denver, CO 80217 ATTN: Mr. Eddie T. Seo	(1)
Bell Laboratories 600 Mountain Avenue Murray Hill, NJ 07974 ATTN: Dr. J.J. Auborn, Rm 1A-317	(1)	Mail Stop 8C-62 Boeing Aerospace Company P.O. Box 3999 Seattle, WA 98124 ATTN: Mr. Sidney Gross	(1)
Stonehart Associates, Inc. 34 Five Fields Road Madison, CT 06443 ATTN: Mr. Thomas Reddy	(1)	Honeywell Technology Center 10701 Lyndale Avenue, South Bloomington, MN 55420 ATTN: Dr. H.V. Venkatasetty	(1)
Jet Propulsion Laboratory 4800 Oak Grove Drive Pasadena, CA 91103 ATTN: Mr. Harvey Frank Mail Stop 198-220	(1)	Jet Propulsion Laboratory-M.S.198-220 4800 Oak Grove Drive Pasadena, CA 91103 ATTN: Mr. Aiji Uchiyama	(1)
Naval Surface Weapons Center White Oak Laboratory, Code R-33 (M/S A026) Silver Spring, MD 20910 ATTN: Dr. D. Ernst	(1)	Naval Surface Weapons Center White Oak Laboratory, Code R-33 Silver Spring, MD 20910 ATTN: Dr. Frank Bis	(1)

DAI
ILM